

Industry	automobile
Work piece	Steering knuckle
Material	Aluminum
What is machined	Different bores have to be deburred forward and backward on one single operation.

Sketch of work piece

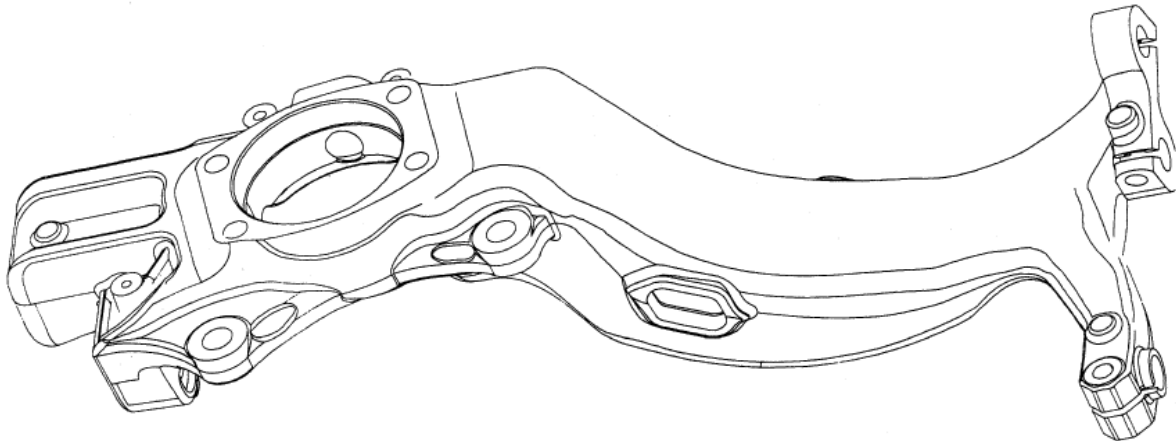

Sketch of tool and work piece

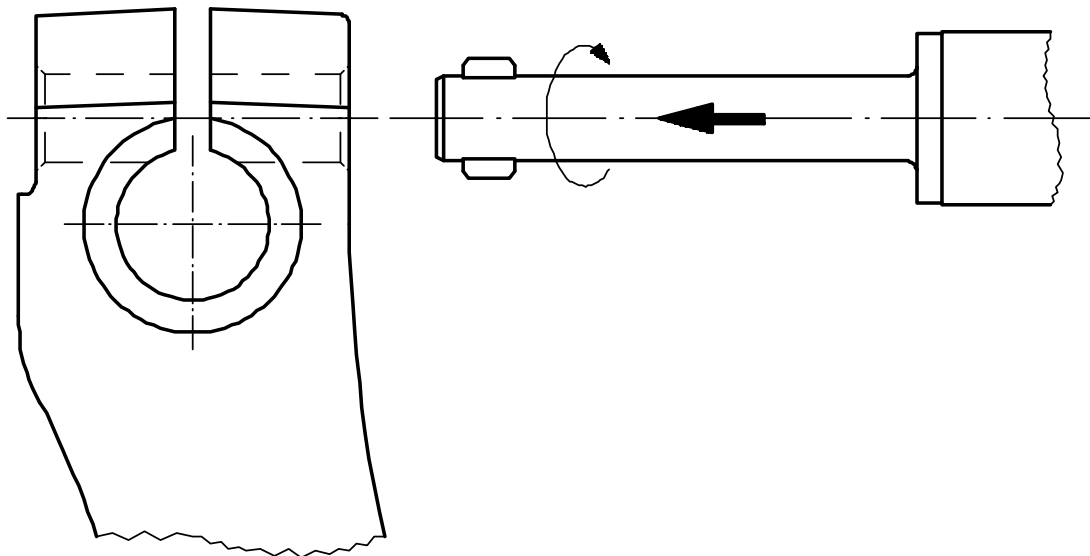

Tool	DEFA tools
Speed	1000 1/min
Feed	0.06 mm/rev
Coolant	Emulsion
Notes	In one single work operation without stopping or reversing the spindle